

**SPECIFICATION
FOR
LCM Module**

MODULE No:	KD028WQRMD039-01
CUSTOMER:	

STARTEK	INITIAL	DATE
PREPARED BY		
CHECKED BY		
APPROVED BY		

CUSTOMER	INITIAL	DATE
APPROVED BY		

Part. No	KD028WQRMD039-01	REV	V1.0	Page 1 of 28
----------	------------------	-----	------	--------------

常备库存 Stock For Sale	长期供货 Long Time supply	支持小量 NO MOQ	品种齐全 In Full Range
------------------------	--------------------------	----------------	-----------------------

Revision History

Date	Rev. No.	Page	Summary
2022.12.02	V1.0	ALL	FIRST ISSUE

常备库存 长期供货 支持小量 品种齐全
Stock For Sale Long Time supply NO MOQ In Full Range

Contents

1. Block Diagram	5
2. Outline dimension	6
3. Input terminal Pin Assignment	7
4. LCD Optical Characteristics	9
4.1 Transmissive mode.....	9
4.2 Reflective mode (Not driving the back light condition).....	9
5. Electrical Characteristics	12
5.1 Absolute Maximum Rating (Ta=25 VSS=0V).....	12
5.2 DC Electrical Characteristics.....	12
5.3 LED Backlight Characteristics.....	13
6. AC Characteristic	15
6.1 DBI Type B (18/16/9/8 bit) Interface Timing Characteristics.....	15
6.2 DBI Type C (SPI) Interface Timing Characteristics.....	17
6.3 RGB Interface Timing Characteristics.....	18
6.4 Reset Timing Characteristics.....	19
7. LCD Module Out-Going Quality Level	20
7.1 VISUAL & FUNCTION INSPECTION STANDARD	20
7.1.1 Inspection conditions.....	20
7.1.2 Definition.....	20
7.1.3 Sampling Plan.....	21
7.1.4 Criteria (Visual).....	22
8. Reliability Test Result	26
9. Cautions and Handling Precautions	27
9.1 Handling and Operating the Module.....	27
9.2 Storage and Transportation.....	27
10. Packing	28

*** Description**

This is a color active matrix TFT (Thin Film Transistor) LCD (liquid crystal display) that uses amorphous silicon TFT as a switching device. This module is composed of a transfective type TFT-LCD Panel, driver circuit, back-light unit. The resolution of a 2.8'TFT-LCD contains 240x400 pixels, and can display up to 65K/262K colors.

*** Features**

General Information Items	Specification	Unit	Note
	Main Panel		
Display area(AA)	36.72(H)*61.2 (V) (2.8 inch)	mm	-
Driver element	TFT active matrix	-	-
Display colors	65K/262K	colors	-
Number of pixels	240(RGB)*400	dots	-
Pixel arrangement	RGB vertical stripe	-	-
Pixel pitch	0.153(H)*0.153(V)	mm	-
Viewing angle	5:00	o'clock	-
Controller IC	ILI9327	-	-
LCM Interface	8/9/16/18Bit MCU 3/4SPI+16/18Bit RGB 3-line/4-line Serial		
Display mode	transfective/ Normally White	-	-
Operating temperature	-20~+70	°C	-
Storage temperature	-30~+80	°C	-

*** Mechanical Information**

Item		Min.	Typ.	Max.	Unit	Note
Module size	Horizontal(H)		44		mm	-
	Vertical(V)		72.5		mm	-
	Depth(D)		2.54		mm	-
Weight			TBD		g	-

1. Block Diagram

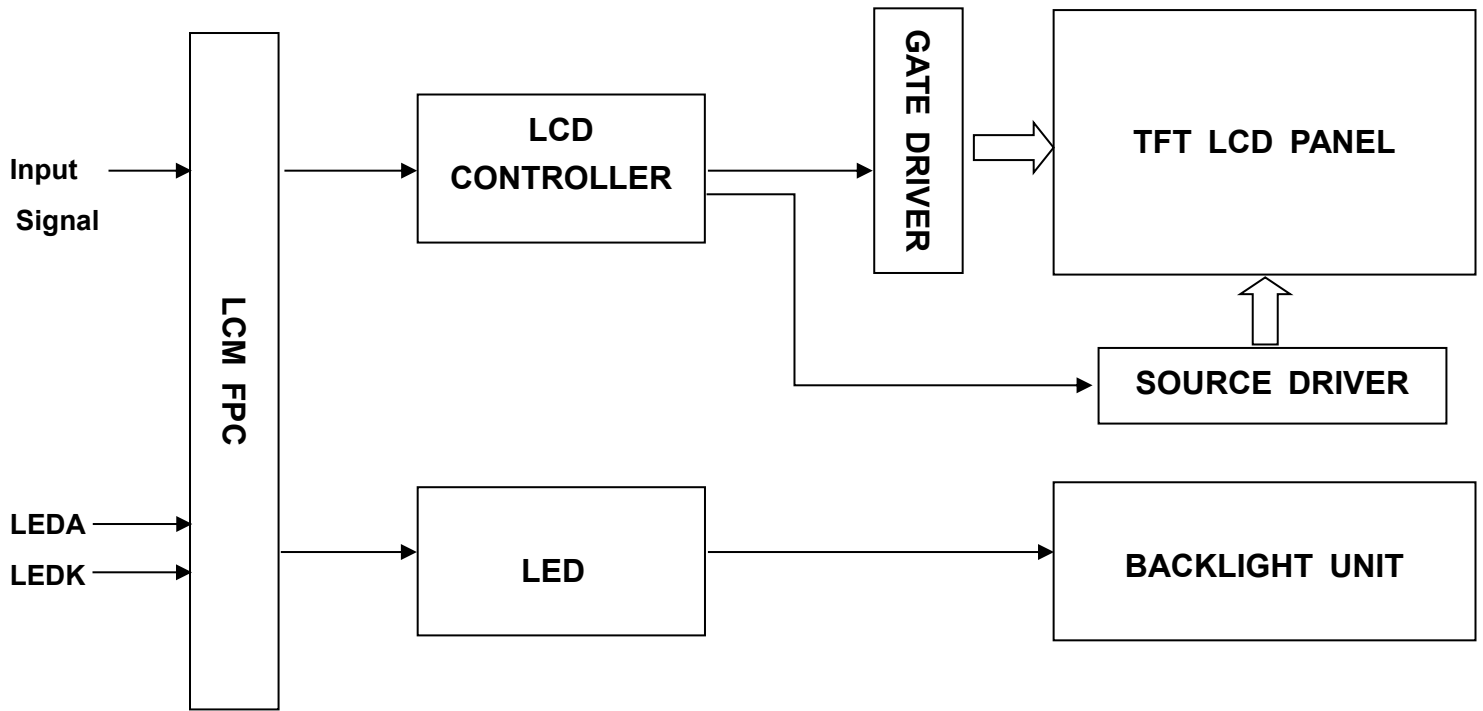

2. Outline dimension

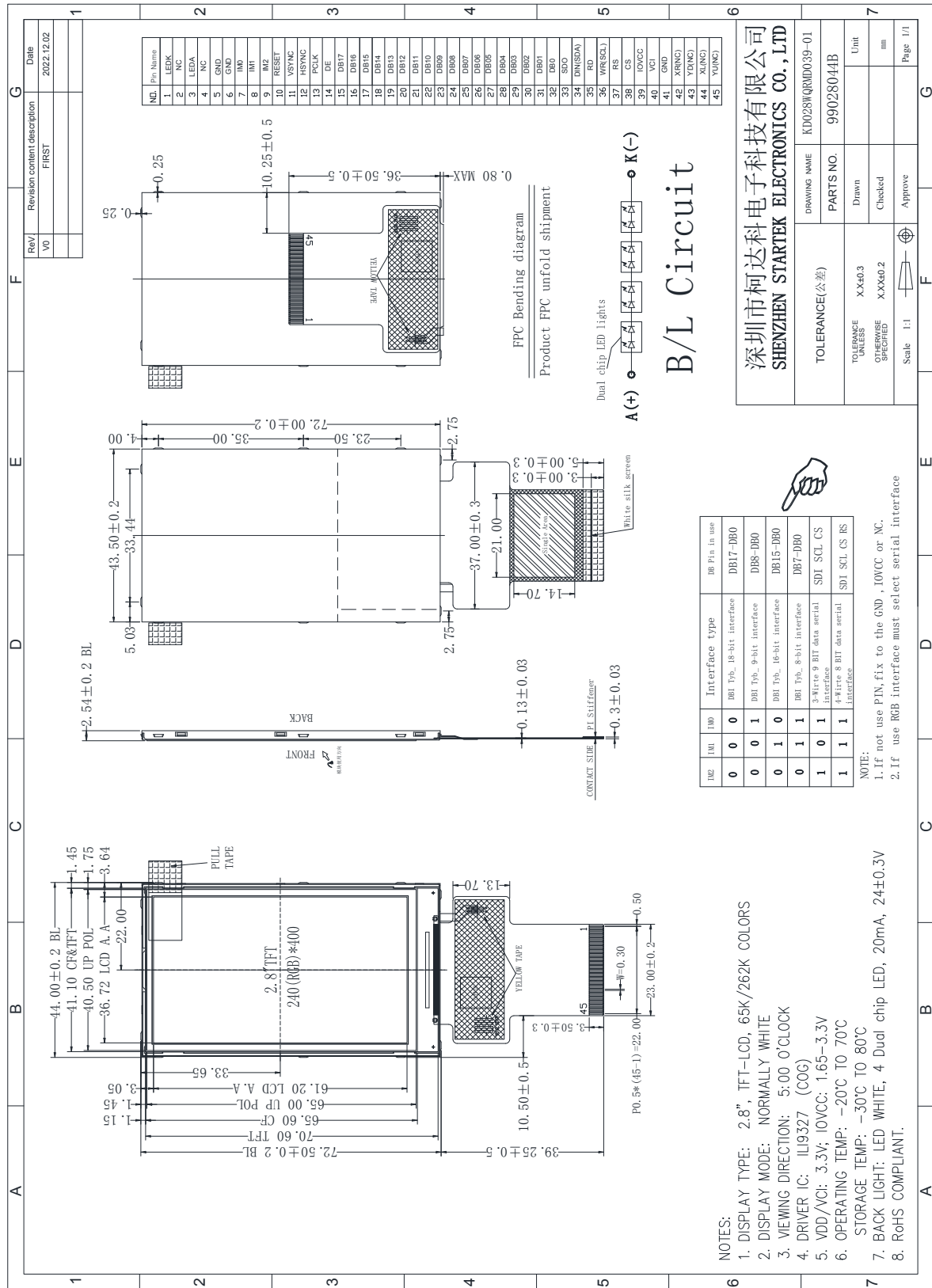

3. Input terminal Pin Assignment

NO.	SYMBOL	DISCRIPTION	I/O
1	LEDK	Cathode pin OF backlight	P
2	NC	--	--
3	LEDA	Anode pin of backlight	P
4	NC	--	--
5	GND	Ground.	P
6	GND	Ground.	P
7	IM0	MPU Parallel interface bus and serial interface select If use RGB Interface must select serial interface. Fix this pin at IOVCC and GND.	I
8	IM1		I
9	IM2		I
10	RESET	This signal will reset the device and must be applied to properly initialize the chip. Signal is low active	I
11	VSYNC	Frame synchronizing signal for RGB interface operation. fix this pin at IOVCC or GND when not in use.	I
12	HSYNC	Line synchronizing signal for RGB interface operation. fix this pin at IOVCC or GND when not in use	I
13	PLCK	Dot clock signal for RGB interface operation Fix this pin at IOVCC or GND when not in use.	I
14	DE	Data enable signal for RGB interface operation. fix this pin at IOVCC or GND when not in use.	I
15-32	DB17-DB0	18-bit parallel bi-directional data bus for MCU system and RGB interface mode . Fix to GND level when not in use	I/O
33	SDO	Serial data output pin in serial bus system interface. If not used, please open this pin.	O
34	DIN(SDA)	Serial data input pin and used for the DBI type C mode. If not used, please connect this pin to ground.	I
35	RD	Read control pin for the DBI interface. If not used, please connect this pin to IOVCC or GND.	I
36	WR(SCL)	Write control pin for the DBI interface. When the DBI type C is selected,this pin is used as serial clock	I

		pin. If not used, please connect this pin to IOVCC or GND.	
37	RS	Display data / Command selection pin D/CX='1': Display data. D/CX='0': Command data. If not used, please fix this pin at GND level.	I
38	CS	Chip select input pin ("Low" enable). When it is not used, please fix this pin at IOVCC or GND.	I
39	IOVCC	Supply voltage for IO(1.65-3.3V)	P
40	VCI	Supply voltage(3.3V).	P
41	GND	Ground.	P
42	XR(NC)	--	--
43	YD(NC)	--	--
44	XL(NC)	--	--
45	YU(NC)	--	--

4. LCD Optical Characteristics

4.1 Transmissive mode

Item	Symbol	Condition	Min.	Typ.	Max.	Unit.	Note	
Transmittance(With Polarizer)	T%	--	0.85	1	--	%		
Contrast Ratio	CR	$\Theta=0$ Normal viewing angle	60	--	--		(1)(2)	
Response time	Rising		T_{R+T_F}	--	30		msec	(1)(3)
	Falling							
Color Gamut	S(%)		23	28	--	%		
Color Filter Chromaticity	White		W_X	0.2321	0.2721	0.3121		(1)(4) CA-310
			W_Y	0.2557	0.2957	0.3357		
	Red		R_X	0.4166	0.4566	0.4966		
			R_Y	0.2616	0.3016	0.3416		
	Green		G_X	0.2765	0.3165	0.3565		
			G_Y	0.4780	0.5180	0.5580		
	Blue	B_X	0.1224	0.1624	0.2024			
		B_Y	0.0770	0.1170	0.1570			
Viewing angle	Hor.	Θ_L	--	30	--		(1)(4)	
		Θ_R	--	30	--			
	Ver.	Θ_U	--	40	--			
		Θ_D	--	30	--			
Option View Direction			5:00					

4.2 Reflective mode (Not driving the back light condition)

Item	Symbol	Condition	Min.	Typ.	Max.	Unit.	Note
Reflection Ratio (With Polarizer)	$R (\theta = \phi = 0^\circ)$	--	5.5	7	--	%	
Reflective Contrast Ratio	$CR(\theta = 0^\circ)$	--	11	--	--		(1)(2)
Color Gamut	S(%)	--	--	5.73	--	%	(1)(3)
Viewing angle	Hor.	Θ_L	$CR \geq 5$	--	30	--	(1)(4)
		Θ_R		--	35	--	
	Ver.	Θ_U		--	30	--	
		Θ_D		--	35	--	

*The data comes from the LCD specification.

Measuring Condition

Measuring surrounding : dark room
 Ambient temperature : 25±2°C
 15min. warm-up time.

Measuring Equipment

FPM520 of Westar Display technologies, INC., which utilized SR-3 for Chromaticity and BM-5A for other optical characteristics.

Note (1): Definition of Viewing Angle :

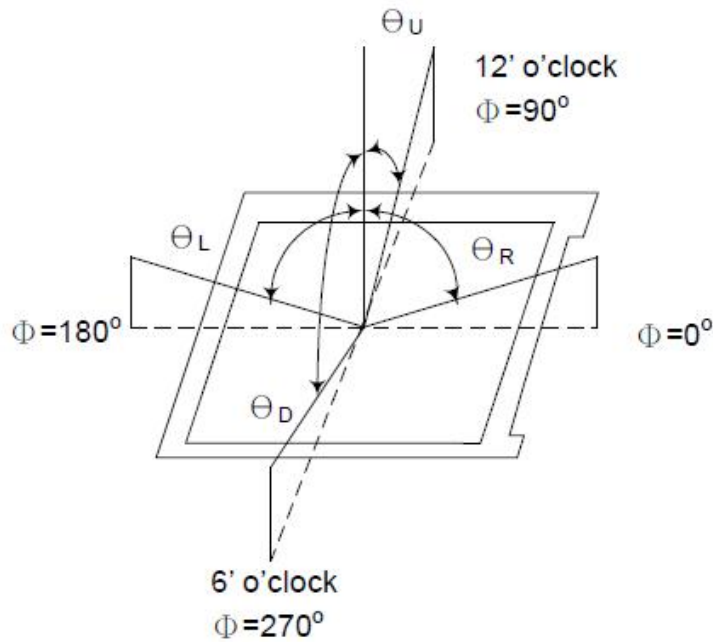

Note (2): Definition of Contrast Ratio(CR) :measured at the center point of panel

$$CR = \frac{\text{Luminance with all pixels white}}{\text{Luminance with all pixels black}}$$

Part. No	KD028WQRMD039-01	REV	V1.0	Page 10 of 28
----------	------------------	-----	------	---------------

常备库存
Stock For Sale

长期供货
Long Time supply

支持小量
NO MOQ

品种齐全
In Full Range

Note (3): Response Time

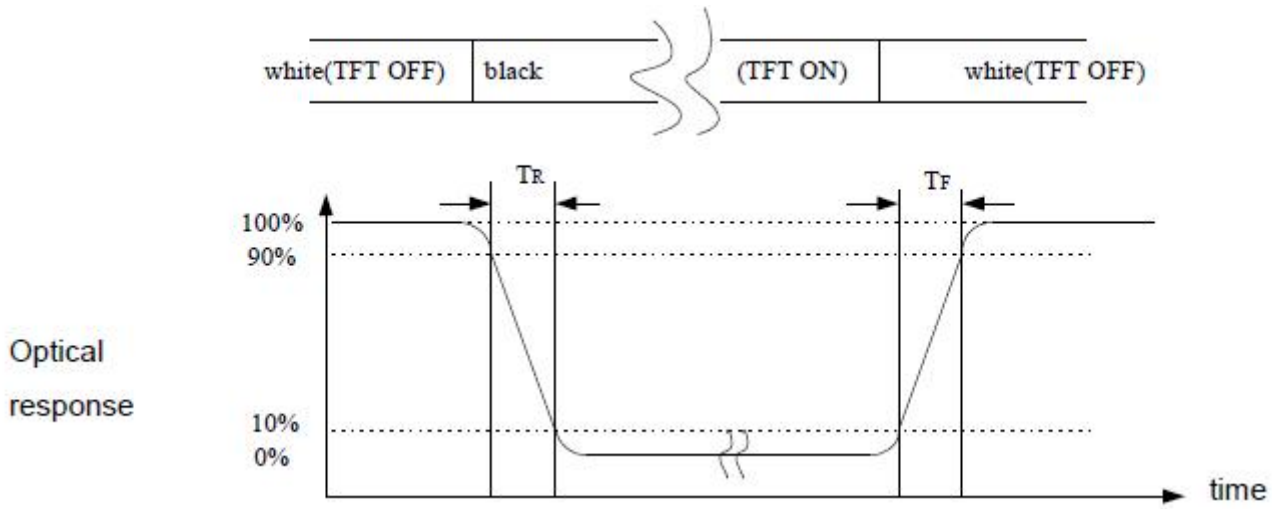

Note (4): Definition of optical measurement setup

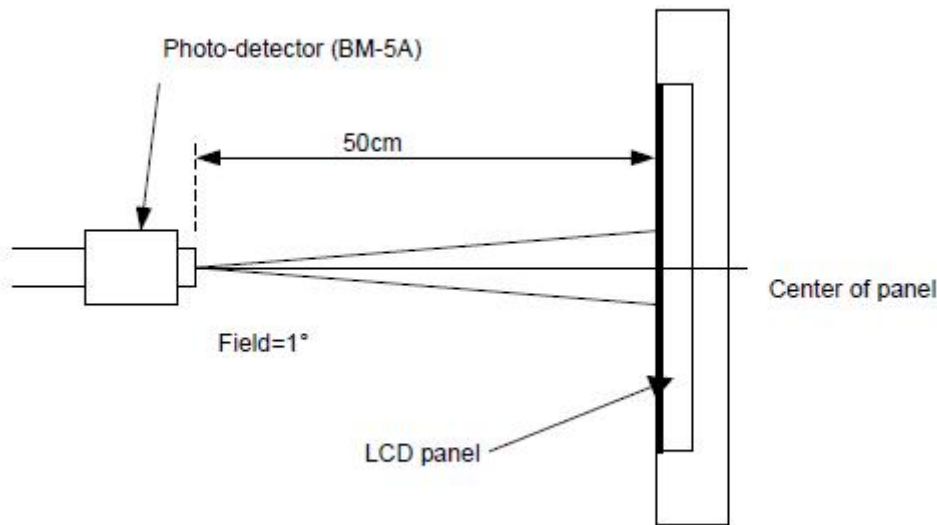

Part. No	KD028WQRMD039-01	REV	V1.0	Page 11 of 28
----------	------------------	-----	------	---------------

常备库存
Stock For Sale

长期供货
Long Time supply

支持小量
NO MOQ

品种齐全
In Full Range

5. Electrical Characteristics

5.1 Absolute Maximum Rating (Ta=25 VSS=0V)

Characteristics	Symbol	Min.	Max.	Unit
Digital Supply Voltage	VCI	-0.3	4.6	V
Digital interface supply Voltage	IOVCC	-0.3	4.6	V
Operating temperature	T _{OP}	-20	+70	°C
Storage temperature	T _{ST}	-30	+80	°C

NOTE: If the absolute maximum rating of even is one of the above parameters is exceeded even momentarily, the quality of the product may be degraded. Absolute maximum ratings, therefore, specify the values exceeding which the product may be physically damaged. Be sure to use the product within the range of the absolute maximum ratings.

5.2 DC Electrical Characteristics

Characteristics	Symbol	Min.	Typ.	Max.	Unit	Note
Digital Supply Voltage	VCI	2.5	2.8	3.6	V	
Digital interface supply Voltage	IOVCC	1.65	1.8	3.6	V	
Normal mode Current consumption	IDD	--	6	12	mA	
Level input voltage	V _{IH}	0.7IOVCC		IOVCC	V	
	V _{IL}	GND		0.3IOVCC	V	
Level output voltage	V _{OH}	0.8IOVCC		IOVCC	V	
	V _{OL}	GND		0.2IOVCC	V	

5.3 LED Backlight Characteristics

The back-light system is edge-lighting type with 4 Dual chips White LED

Item	Symbol	Min.	Typ.	Max.	Unit	Note
Forward Current	I_F	15	20	--	mA	
Forward Voltage	V_F	--	24	--	V	
LCM Luminance	L_V	100	120	--	cd/m ²	Note3
LED life time	Hr	30000	--	--	Hour	Note1,2
Uniformity	AVg	80	--	--	%	Note3

Note (1) LED life time (Hr) can be defined as the time in which it continues to operate under the condition:

$T_a=25\pm3\text{ }^\circ\text{C}$, typical IL value indicated in the above table until the brightness becomes less than 50%.

Note (2) The “LED life time” is defined as the module brightness decrease to 50% original brightness at $T_a=25\text{ }^\circ\text{C}$ and $I_L=20\text{mA}$. The LED lifetime could be decreased if operating I_L is larger than 20mA. The constant current driving method is suggested.

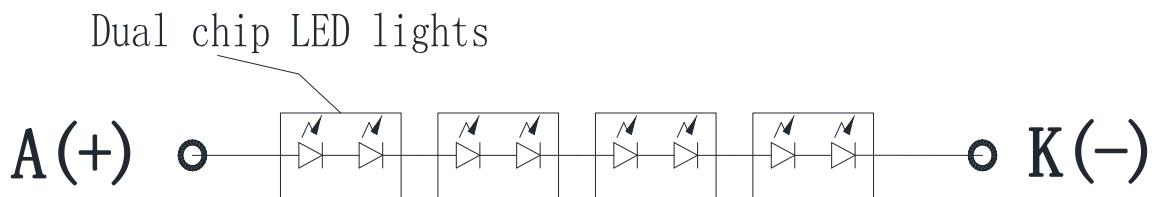

B/L Circuit

NOTE 3: Luminance Uniformity of these 9 points is defined as below:

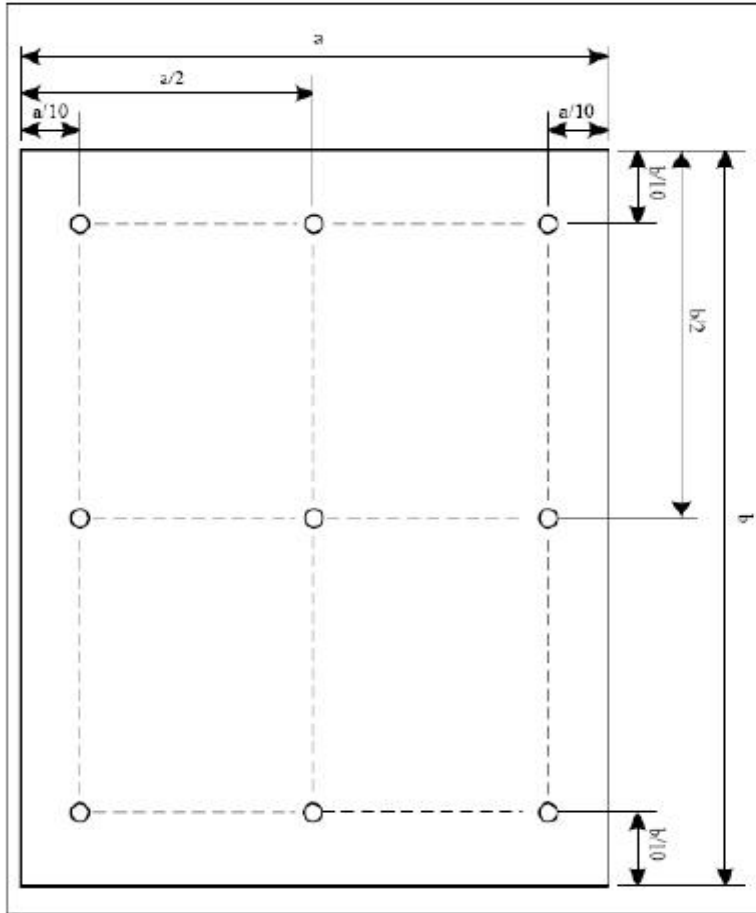

$$\text{Uniformity} = \frac{\text{minimum luminance in 9 points (1-9)}}{\text{maximum luminance in 9 points (1-9)}}$$

$$\text{Luminance} = \frac{\text{Total Luminance of 9 points}}{9}$$

Part. No	KD028WQRMD039-01	REV	V1.0	Page 14 of 28
----------	------------------	-----	------	---------------

常备库存
Stock For Sale

长期供货
Long Time supply

支持小量
NO MOQ

品种齐全
In Full Range

6. AC Characteristic

6.1 DBI Type B (18/16/9/8 bit) Interface Timing Characteristics

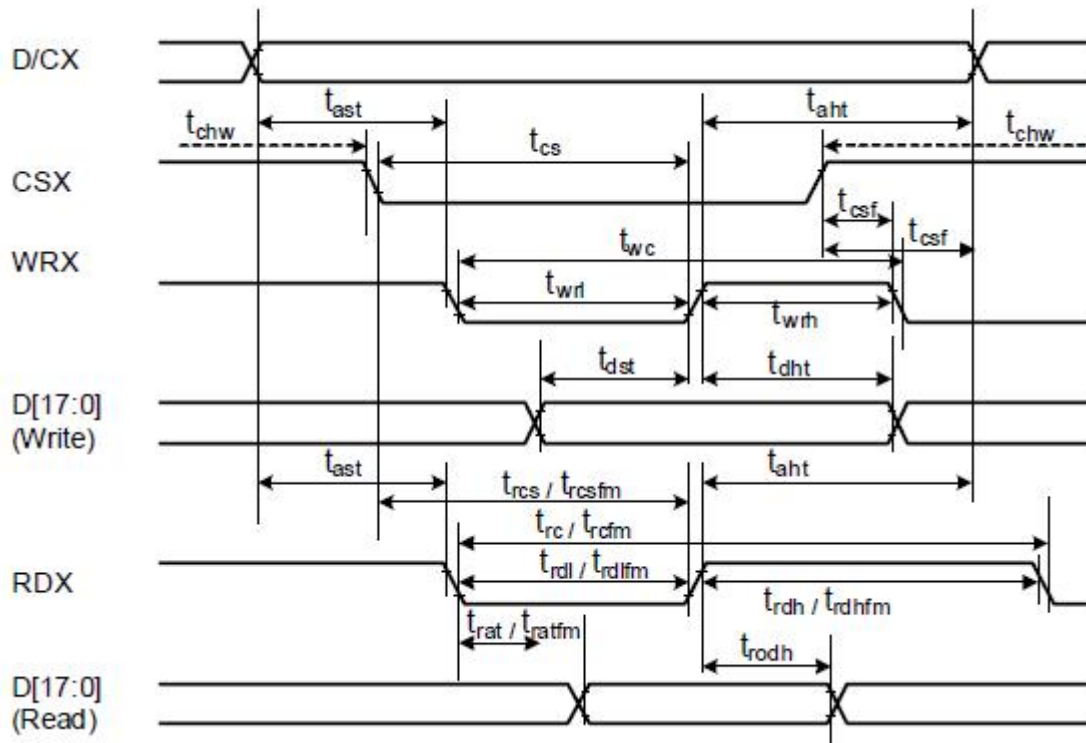

Signal	Symbol	Parameter	min	max	Unit	Description
D/CX	t _{ast}	Address setup time	0	-	ns	
	t _{ah}	Address hold time (Write/Read)	10	-	ns	
CSX	t _{chw}	CSX "H" Pulse Width	0	-	ns	
	t _{cs}	Chip Select setup time (Write)	20	-	ns	
	t _{rcs}	Chip Select setup time (Read ID)	45	-	ns	
	t _{rcsfm}	Chip Select setup time (Read FM)	355	-	ns	
	t _{csf}	Chip Select Wait time (Write/Read)	10	-	ns	
WRX	t _{wc}	Write cycle	80	-	ns	
	t _{wrh}	Write Control pulse H duration	25	-	ns	
	t _{wrl}	Write Control pulse L duration	25	-	ns	
RDX (ID)	t _{rc}	Read cycle (ID)	160	-	ns	
	t _{rdh}	Read Control pulse H duration (ID)	90	-	ns	
	t _{rdl}	Read Control pulse L duration (ID)	45	-	ns	
RDX (FM)	t _{rcfm}	Read cycle (FM)	450	-	ns	
	t _{rdhfm}	Read Control pulse H duration (FM)	90	-	ns	
	t _{rdlfm}	Read Control pulse L duration (FM)	355	-	ns	
DB[17:0], DB[15:0], DB[8:0], DB[7:0]	t _{dst}	Data setup time	10	-	ns	For maximum CL=30pF For minimum CL=8pF
	t _{dht}	Data hold time	10	-	ns	
	t _{rat}	Read access time (ID)	-	40	ns	
	t _{ratfm}	Read access time (FM)	-	340	ns	
	t _{odh}	Output disable time	20	-	ns	

Note: $T_a = -30$ to 70 °C, $V_{DDI} = 1.65V$ to $3.3V$, $V_{DD} = 2.5V$ to $3.0V$, $DGND = 0V$



CSX timings:

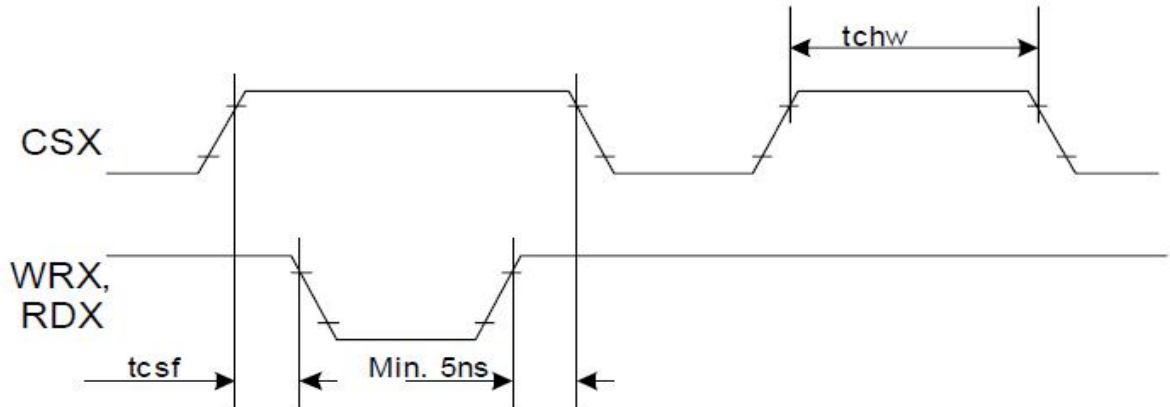

Note: Logic high and low levels are specified as 30% and 70% of V_{DDI} for Input signals.

Write to read or read to write timings:

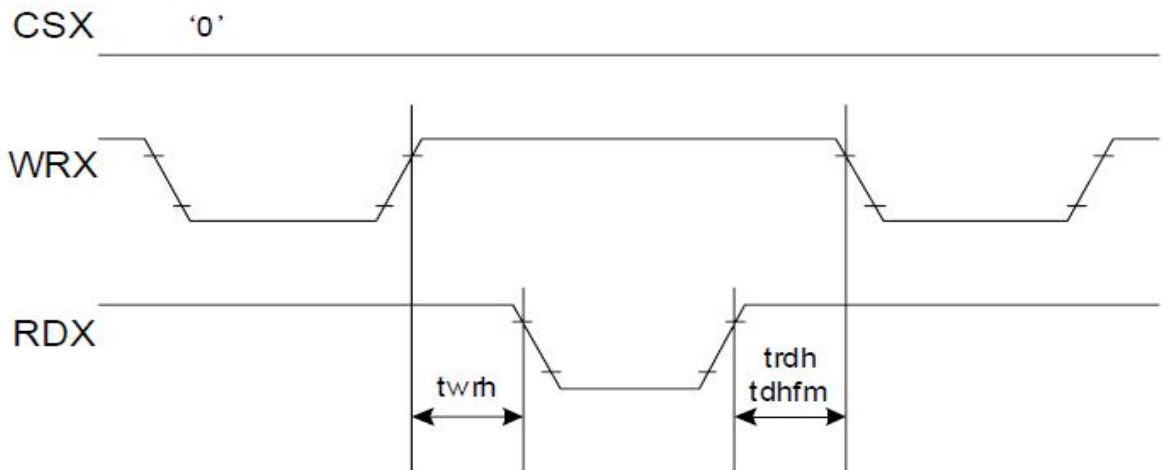

Note: Logic high and low levels are specified as 30% and 70% of V_{DDI} for Input signals.

Part. No	KD028WQRMD039-01	REV	V1.0	Page 16 of 28
----------	------------------	-----	------	---------------

常备库存
Stock For Sale

长期供货
Long Time supply

支持小量
NO MOQ

品种齐全
In Full Range

6.2 DBI Type C (SPI) Interface Timing Characteristics

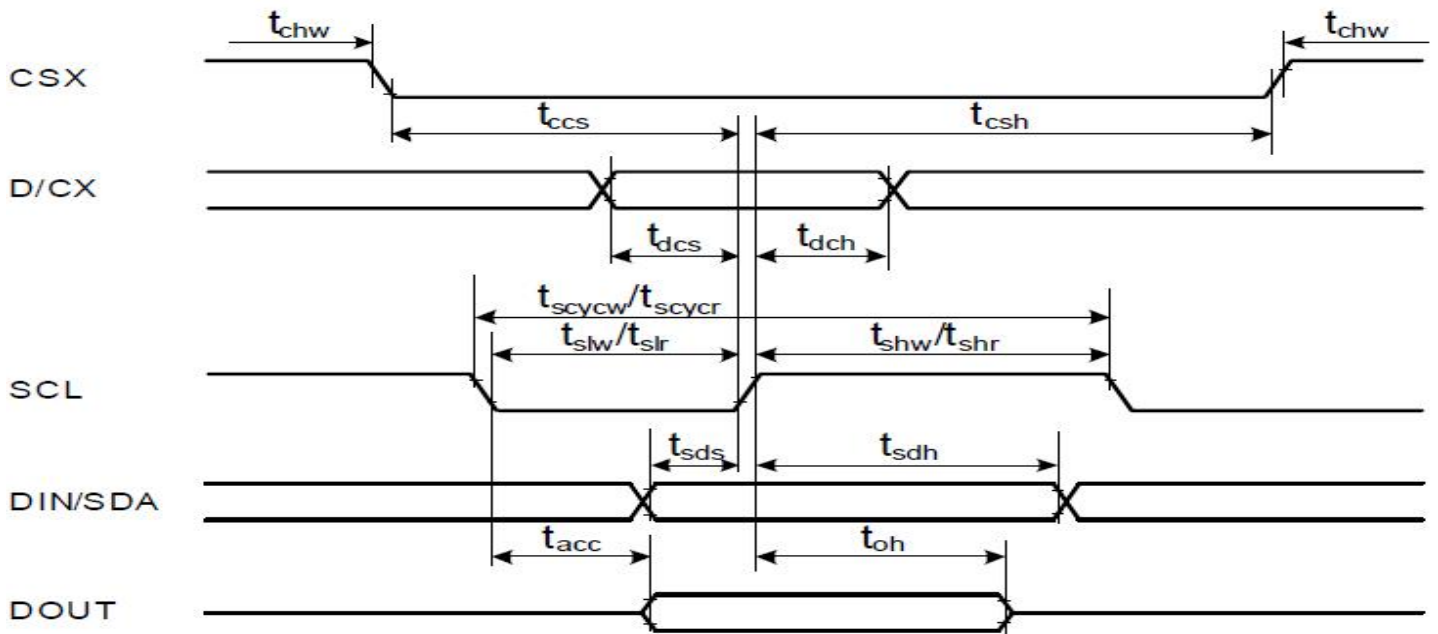

Signal	Symbol	Parameter	min	max	Unit	Description
CSX	t_{ccs}	CSX-SCL time (Write)	15	-	ns	
	t_{csh}	CSX-SCL time (Write)	15	-	ns	
	t_{ccs}	CSX-SCL time (Read)	60	-	ns	
	t_{csh}	CSX-SCL time (Read)	60	-	ns	
	t_{chw}	CSX "H" pulse time	40	-	ns	
SCL	t_{scycw}	Serial clock cycle (Write)	60	-	ns	
	t_{shw}	SCL "H" pulse width (Write)	15	-	ns	
	t_{slw}	SCL "L" pulse width (Write)	15	-	ns	
	t_{scycr}	Serial clock cycle (Read GRAM)	300	-	ns	
	t_{shr}	SCL "H" pulse width (Read GRAM)	110	-	ns	
	t_{slr}	SCL "L" pulse width (Read GRAM)	110	-	ns	
	t_{scycr}	Serial clock cycle (Read ID)	150	-	ns	
	t_{shr}	SCL "H" pulse width (Read GRAM)	54	-	ns	
D/CX	t_{dcs}	D/CX setup time	7	-	ns	
	t_{dch}	D/CX hold time	7	-	ns	
SDA (Input) (Output)	t_{acc}	Access time	10	50	ns	For maximum CL=30pF
	t_{oh}	Output disable time	15	50	ns	For minimum CL=8pF
	t_{sds}	Data setup time	7	-	ns	
	t_{sdh}	Data hold time	7	-	ns	

Note: $T_a = -30$ to 70 °C, $V_{DDI} = 1.65V$ to $3.3V$, $V_{DD} = 2.5V$ to $3.0V$, $AGND = DGND = 0V$

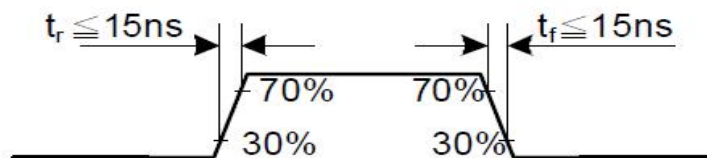

Part. No	KD028WQRMD039-01	REV	V1.0	Page 17 of 28
----------	------------------	-----	------	---------------

常备库存
Stock For Sale

长期供货
Long Time supply

支持小量
NO MOQ

品种齐全
In Full Range

6.3 RGB Interface Timing Characteristics

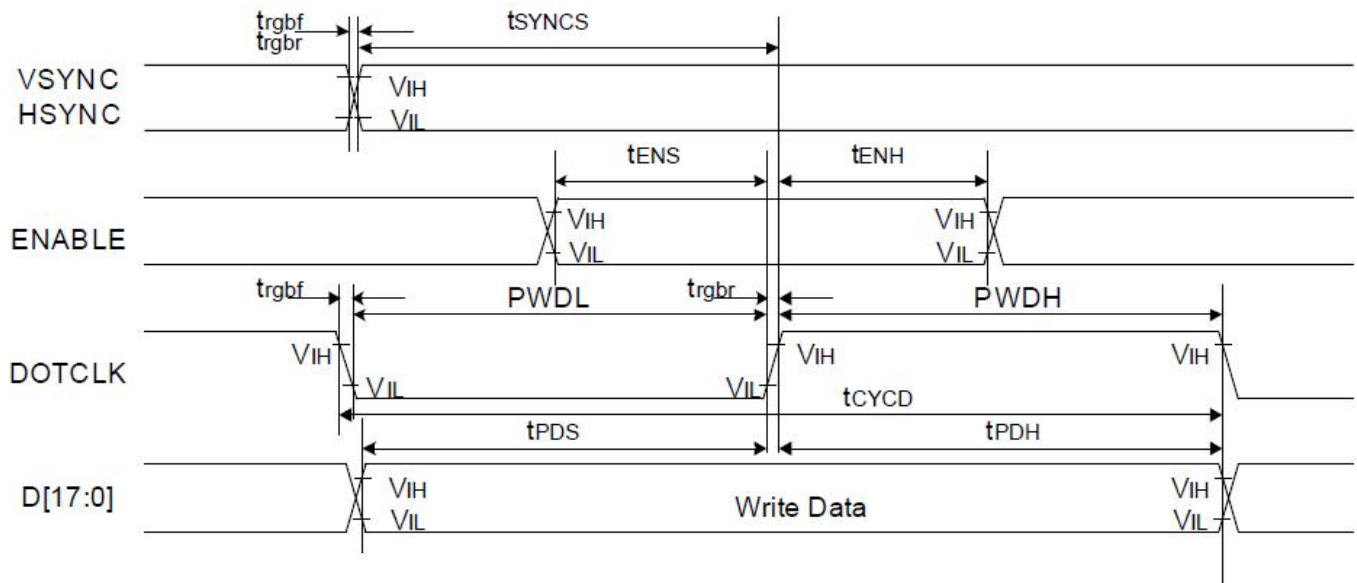

Signal	Symbol	Parameter	min	max	Unit	Description
VSYNC / HSYNC	t_{SYNCS}	VSYNC/HSYNC setup time	15	-	ns	18/16-bit bus RGB interface mode
	t_{SYNCH}	VSYNC/HSYNC hold time	15	-	ns	
ENABLE	t_{ENS}	ENABLE setup time	15	-	ns	
	t_{ENH}	ENABLE hold time	15	-	ns	
D[17:0]	t_{POS}	Data setup time	15	-	ns	
	t_{POH}	Data hold time	15	-	ns	
DOTCLK	PWDH	DOTCLK high-level period	15	-	ns	
	PWDL	DOTCLK low-level period	15	-	ns	
	t_{CYCD}	DOTCLK cycle time	100	-	ns	
	t_{rgb}, t_{rgb}	DOTCLK, HSYNC, VSYNC rise/fall time	-	15	ns	
VSYNC / HSYNC	t_{SYNCS}	VSYNC/HSYNC setup time	15	-	ns	6-bit bus RGB interface mode
	t_{SYNCH}	VSYNC/HSYNC hold time	15	-	ns	
ENABLE	t_{ENS}	ENABLE setup time	15	-	ns	
	t_{ENH}	ENABLE hold time	15	-	ns	
D[17:0]	t_{POS}	Data setup time	15	-	ns	
	t_{POH}	Data hold time	15	-	ns	
DOTCLK	PWDH	DOTCLK high-level pulse period	15	-	ns	
	PWDL	DOTCLK low-level pulse period	15	-	ns	
	t_{CYCD}	DOTCLK cycle time	100	-	ns	
	t_{rgb}, t_{rgb}	DOTCLK, HSYNC, VSYNC rise/fall time	-	15	ns	

6.4 Reset Timing Characteristics

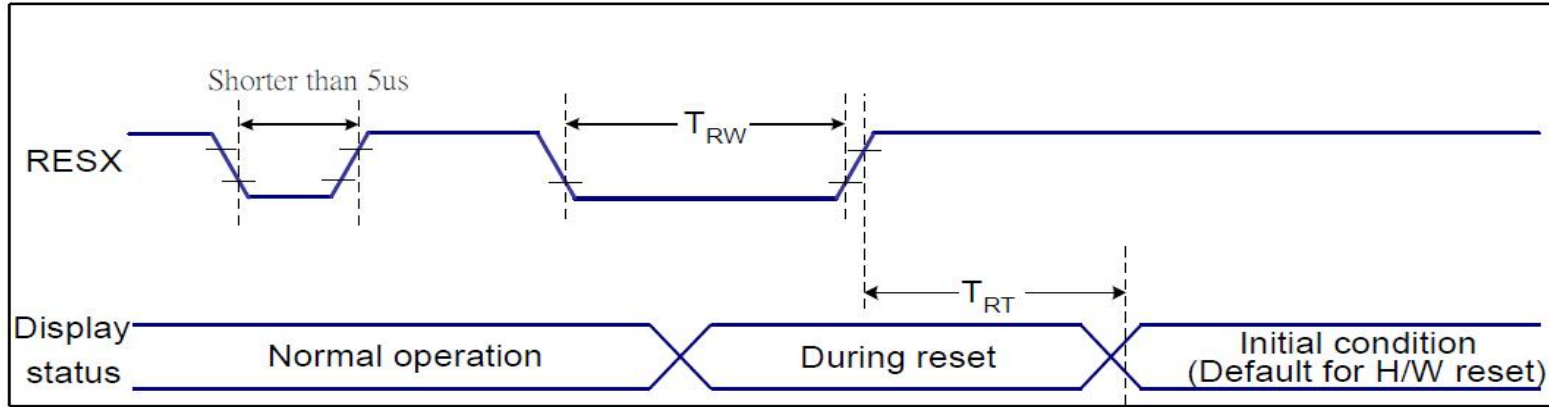

Figure 7 Reset Timing

VDDI=1.65 to 3.3V, VDD=2.4 to 3.3V, AGND=DGND=0V, Ta=-30 ~ 70 °C

Related Pins	Symbol	Parameter	MIN	MAX	Unit
RESX	TRW	Reset pulse duration	10	-	us
	TRT	Reset cancel	-	5 (Note 1, 5)	ms
			-	120 (Note 1, 6, 7)	ms

Table 8 Reset Timing

Notes:

- The reset cancel includes also required time for loading ID bytes, VCOM setting and other settings from NVM (or similar device) to registers. This loading is done every time when there is HW reset cancel time (tRT) within 5 ms after a rising edge of RESX.
- Spike due to an electrostatic discharge on RESX line does not cause irregular system reset according to the table below:

RESX Pulse	Action
Shorter than 5us	Reset Rejected
Longer than 9us	Reset
Between 5us and 9us	Reset starts

- During the Resetting period, the display will be blanked (The display is entering blanking sequence, which maximum time is 120 ms, when Reset Starts in Sleep Out –mode. The display remains the blank state in Sleep In –mode.) and then return to Default condition for Hardware Reset.

4. Spike Rejection also applies during a valid reset pulse as shown below:

Part. No	KD028WQRMD039-01	REV	V1.0	Page 19 of 28
----------	------------------	-----	------	---------------

常备库存
Stock For Sale

长期供货
Long Time supply

支持小量
NO MOQ

品种齐全
In Full Range

7. LCD Module Out-Going Quality Level

7.1 VISUAL & FUNCTION INSPECTION STANDARD

7.1.1 Inspection conditions

Inspection performed under the following conditions is recommended.

Temperature : $25\pm 5^{\circ}\text{C}$

Humidity : $65\%\pm 10\%\text{RH}$

Viewing Angle : Normal viewing Angle.

Illumination: Single fluorescent lamp (300 to 700Lux)

Viewing distance:30-50cm

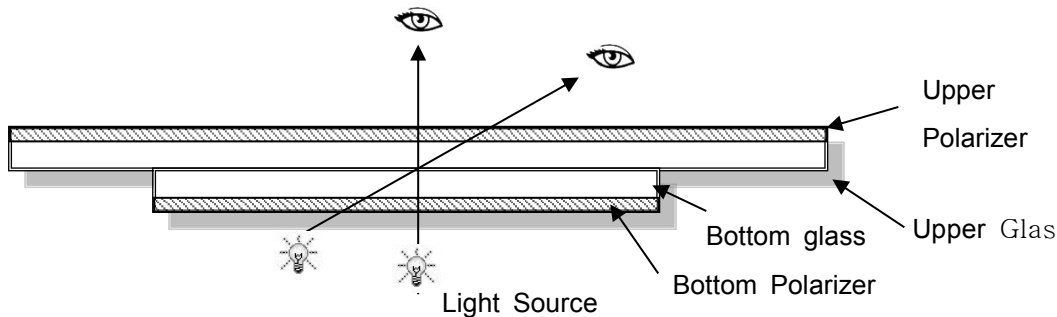

7.1.2 Definition

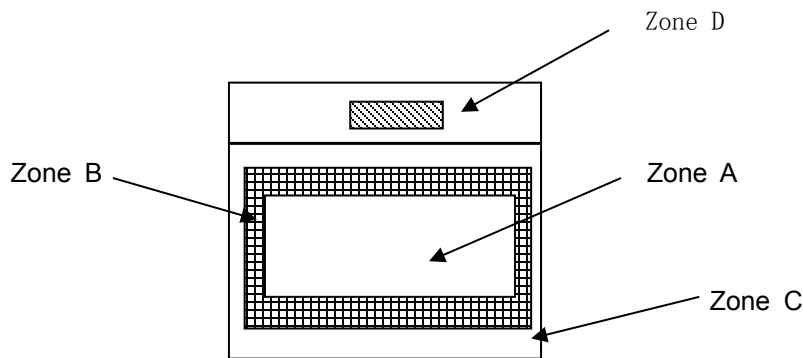

Zone A : Effective Viewing Area(Character or Digit can be seen)

Zone B : Viewing Area except Zone A

Zone C : Outside (Zone A+Zone B) which can not be seen after assembly by customer

Zone D : IC Bonding Area

Note:As a general rule ,visual defects in Zone C can be ignored when it doesn't effect product function or appearance after assembly by customer

Part. No	KD028WQRMD039-01	REV	V1.0	Page 20 of 28
----------	------------------	-----	------	---------------

常备库存
Stock For Sale

长期供货
Long Time supply

支持小量
NO MOQ

品种齐全
In Full Range

7.1.3 Sampling Plan

According to GB/T 2828-2003 ; , normal inspection, Class II

AQL:

Major defect	Minor defect
0.65	1.5

LCD: Liquid Crystal Display , LCM: Liquid Crystal Module,

No	Items to be inspected	Criteria	Classification of defects
1	Functional defects	1) No display, Open or miss line 2) Display abnormally, Short 3) Backlight no lighting, abnormal lighting. etc...	Major
2	Missing	Missing components and etc...	
3	Outline dimension	Overall outline dimension beyond the drawing is not allowed, deformation and etc...	
4	Color tone	Color unevenness, refer to limited sample	Minor
5	Spot/Line defect	Light dot, Dim spot, (Note1) Polarizer Air Bubble, Polarizer accidented spot and etc.	
6	Soldering appearance	Good soldering , Peeling off is not allowed and etc.	
7	LCD/Polarizer	Black/White spot/line, scratch, crack, etc.	



Note1: a) Light dot: Dots appear bright and unchanged in size in which LCD panel is displaying under black pattern.

b) Dim dot: Dots appear dark and unchanged in size in which LCD panel is displaying under pure red, green, blue picture.

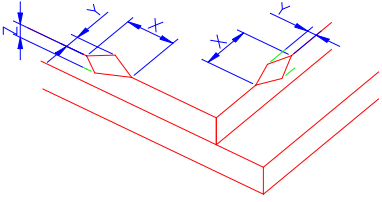
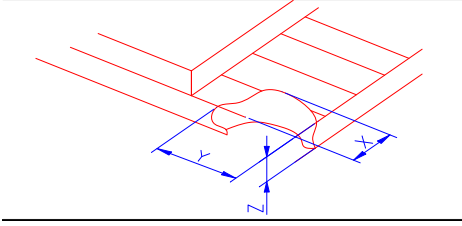
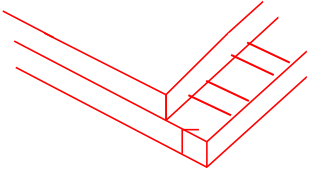
7.1.4 Criteria (Visual)

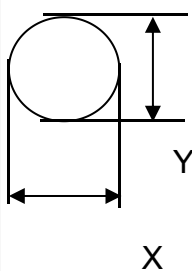
Number	Items	Criteria(mm)						
1.0 LCD Crack/Broken NOTE: X: Length Y: Width Z: Height L: Length of IT O, T: Height of LCD	(1) The edge of LCD broken	 <table border="1" data-bbox="756 667 1455 815"> <thead> <tr> <th>X</th> <th>Y</th> <th>Z</th> </tr> </thead> <tbody> <tr> <td>≤3.0mm</td> <td><Inner border line of the seal</td> <td>≤T</td> </tr> </tbody> </table>	X	Y	Z	≤3.0mm	<Inner border line of the seal	≤T
X	Y	Z						
≤3.0mm	<Inner border line of the seal	≤T						
	(2)LCD corner broken	 <table border="1" data-bbox="836 1124 1375 1223"> <thead> <tr> <th>X</th> <th>Y</th> <th>Z</th> </tr> </thead> <tbody> <tr> <td>≤3.0mm</td> <td>≤L</td> <td>≤T</td> </tr> </tbody> </table>	X	Y	Z	≤3.0mm	≤L	≤T
X	Y	Z						
≤3.0mm	≤L	≤T						
	(3) LCD crack	 <p style="text-align: center;">Crack Not allowed</p>						

2.0	Spot defect	① light dot (black/white spot , pinhole, stain, etc.)			
	 <p style="text-align: center;">$\Phi = (X+Y)/2$</p>	Zone	Acceptable Qty		
		Size (mm)	A	B	C
		$\Phi \leq 0.15$	Ignore		
		$0.15 < \Phi \leq 0.25$	3(distance ≥ 6 mm)		
	$0.25 < \Phi \leq 0.4$	2(distance ≥ 6 mm)			
	$\Phi > 0.4$	0			
		② Dim spot (light leakage, dent, dark spot, etc)			
		Zone	Acceptable Qty		
		Size (mm)	A	B	C
		$\Phi \leq 0.15$	Ignore		
		$0.15 < \Phi \leq 0.25$	3(distance ≥ 6 mm)		
		$0.25 < \Phi \leq 0.4$	2(distance ≥ 6 mm)		
		$\Phi > 0.4$	0		
		③ Polarizer accidented spot			
		Zone	Acceptable Qty		
		Size (mm)	A	B	C
		$\Phi \leq 0.2$	Ignore		
		$0.2 < \Phi \leq 0.5$	2(distance ≥ 6 mm)		
		$\Phi > 0.5$	0		
		④ Polarizer Bubble			
		Zone	Acceptable Qty		
		Size (mm)	A	B	C
		$\Phi \leq 0.2$	Ignore		
		$0.2 < \Phi \leq 0.4$	3(distance ≥ 6 mm)		
		$\Phi > 0.4$	0		

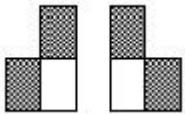
3.0	LCD Pixel defect	<p>Pixel bad points</p> <table border="1"> <thead> <tr> <th data-bbox="539 309 730 360">Item</th> <th data-bbox="730 309 1246 360">Zone A</th> <th data-bbox="1246 309 1497 360">Acceptable Qt</th> </tr> </thead> <tbody> <tr> <td data-bbox="539 360 730 521" rowspan="3">Bright dot</td> <td data-bbox="730 360 1246 416">Random</td> <td data-bbox="1246 360 1497 416">N≤2</td> </tr> <tr> <td data-bbox="730 416 1246 472">2 dots adjacent</td> <td data-bbox="1246 416 1497 472">N≤0</td> </tr> <tr> <td data-bbox="730 472 1246 521">3 dots adjacent</td> <td data-bbox="1246 472 1497 521">N≤0</td> </tr> <tr> <td data-bbox="539 521 730 689" rowspan="3">Dark dot</td> <td data-bbox="730 521 1246 577">Random</td> <td data-bbox="1246 521 1497 577">N≤2</td> </tr> <tr> <td data-bbox="730 577 1246 633">2 dots adjacent</td> <td data-bbox="1246 577 1497 633">N≤0</td> </tr> <tr> <td data-bbox="730 633 1246 689">3 dots adjacent</td> <td data-bbox="1246 633 1497 689">N≤0</td> </tr> <tr> <td data-bbox="539 689 730 1003">Distance</td> <td data-bbox="730 689 1246 1003"> 1. Minimum Distance Between Bright dots. 2. Minimum Distance Between dark dots 3. Minimum Distance Between dark and bright dot. </td> <td data-bbox="1246 689 1497 1003">5mm</td> </tr> <tr> <td colspan="2" data-bbox="539 1003 1246 1059">Total bright and dark dot</td> <td data-bbox="1246 1003 1497 1059">N≤4</td> </tr> </tbody> </table> <p>Note:</p> <p>A) Bright dot: Dots appear bright and unchanged in size in which LCD panel is displaying under black pattern.</p> <p>B) Dark dot: Dots appear dark and unchanged in size in which LCD panel is displaying under pure red, green, blue picture.</p> <p>C) 2 dot adjacent = 1 pair = 2 dots</p> <p>Picture:</p> <div style="display: flex; justify-content: space-around; align-items: flex-start;"> <div style="text-align: center;">  <p>2 dot adjacent</p> </div> <div style="text-align: center;">  <p>2 dot adjacent</p> </div> <div style="text-align: center;">  <p>2 dot adjacent (vertical)</p> </div> <div style="text-align: center;">  <p>2 dot adjacent (slant)</p> </div> </div>	Item	Zone A	Acceptable Qt	Bright dot	Random	N≤2	2 dots adjacent	N≤0	3 dots adjacent	N≤0	Dark dot	Random	N≤2	2 dots adjacent	N≤0	3 dots adjacent	N≤0	Distance	1. Minimum Distance Between Bright dots. 2. Minimum Distance Between dark dots 3. Minimum Distance Between dark and bright dot.	5mm	Total bright and dark dot		N≤4
Item	Zone A	Acceptable Qt																							
Bright dot	Random	N≤2																							
	2 dots adjacent	N≤0																							
	3 dots adjacent	N≤0																							
Dark dot	Random	N≤2																							
	2 dots adjacent	N≤0																							
	3 dots adjacent	N≤0																							
Distance	1. Minimum Distance Between Bright dots. 2. Minimum Distance Between dark dots 3. Minimum Distance Between dark and bright dot.	5mm																							
Total bright and dark dot		N≤4																							

4.0	Line defect (LCD /Polarizer backlight black/white line, scratch, stain)  W: width, L : length N : Count	<table border="1"> <thead> <tr> <th rowspan="2">Width(mm)</th> <th rowspan="2">Length(m)</th> <th colspan="3">Acceptable Qty</th> </tr> <tr> <th>A</th> <th>B</th> <th>C</th> </tr> </thead> <tbody> <tr> <td>$\Phi \leq 0.03$</td> <td>Ignore</td> <td colspan="2">Ignore</td> <td rowspan="3">Ignore</td> </tr> <tr> <td>$0.03 < W \leq 0.04$</td> <td>$L \leq 3.0$</td> <td colspan="2">$N \leq 2$</td> </tr> <tr> <td>$0.04 < W \leq 0.05$</td> <td>$L \leq 2.0$</td> <td colspan="2">$N \leq 1$</td> </tr> <tr> <td>$W > 0.05$</td> <td colspan="4">Define as spot defect</td> </tr> </tbody> </table>	Width(mm)	Length(m)	Acceptable Qty			A	B	C	$\Phi \leq 0.03$	Ignore	Ignore		Ignore	$0.03 < W \leq 0.04$	$L \leq 3.0$	$N \leq 2$		$0.04 < W \leq 0.05$	$L \leq 2.0$	$N \leq 1$		$W > 0.05$	Define as spot defect			
		Width(mm)			Length(m)	Acceptable Qty																						
			A	B		C																						
		$\Phi \leq 0.03$	Ignore	Ignore		Ignore																						
		$0.03 < W \leq 0.04$	$L \leq 3.0$	$N \leq 2$																								
$0.04 < W \leq 0.05$	$L \leq 2.0$	$N \leq 1$																										
$W > 0.05$	Define as spot defect																											
5.0	Electronic Components SMT.	Not allow missing parts, solderless connection, cold solder joint, mismatch, The positive and negative polarity opposite																										
6.0	Display color & Brightness.	1. Color: Measuring the color coordinates, The measurement standard according to the datasheet or samples. 2. Brightness: Measuring the brightness of White screen, The measurement standard according to the datasheet or Samples.																										
7.0	LCD Mura/Waving/ Hot spot	Not visible through 5% ND filter in 50% gray or judge by limit sample if necessary.																										

Criteria (functional items)

Number	Items	Criteria (mm)
1	No display	Not allowed
2	Missing segment	Not allowed
3	Short	Not allowed
4	Backlight no lighting	Not allowed

8. Reliability Test Result

Item	Condition	Inspection after test
High Temperature Operating	70°C,96H	Inspection after 2~4hours storage at room temperature, the sample shall be free from defects: 1.Air bubble in the LCD; 2.Non-display; 3.Missing segments/line; 4.Glass crack; 5.Current IDD is twice higher than initial value.
Low Temperature Operating	-20°C, 96HR	
High Temperature Storage	80°C, 96HR	
Low Temperature Storage	-30°C, 96HR	
High Temperature & High Humidity Operating	+60°C, 90% RH ,96 hours.	
Thermal Shock (Non-operation)	-10°C,30 min ↔ +60°C,30 min, Change time:5min 20CYC.	
ESD test	C=150pF, R=330,5points/panel Air:±8KV, 5times; Contact:±6KV, 5 times; (Environment: 15°C~35°C, 30%~60%).	
Vibration (Non-operation)	Frequency range:10~55Hz, Stroke:1.5mm Sweep:10Hz~55Hz~10Hz 2 hours for each direction of X.Y.Z. (6 hours for total) (Package condition).	
Box Drop Test	1 Corner 3 Edges 6 faces,80cm(MEDIUM BOX)	

Remark:

- 1.The test samples should be applied to only one test item.
- 2.Sample size for each test item is 5~10pcs.
- 3.For Damp Proof Test, Pure water(Resistance > 10MΩ) should be used.
- 4.In case of malfunction defect caused by ESD damage, if it would be recovered to normal state after resetting, it would be judged as a good part.
- 5.Failure Judgment Criterion: Basic Specification, Electrical Characteristic, Mechanical Characteristic, Optical Characteristic.
6. The color fading mura of polarizing filter should not care.

Part. No	KD028WQRMD039-01	REV	V1.0	Page 26 of 28
----------	------------------	-----	------	---------------

常备库存
Stock For Sale

长期供货
Long Time supply

支持少量
NO MOQ

品种齐全
In Full Range

9. Cautions and Handling Precautions

9.1 Handling and Operating the Module

- (1) When the module is assembled, it should be attached to the system firmly.
Do not warp or twist the module during assembly work.
- (2) Protect the module from physical shock or any force. In addition to damage, this may cause improper operation or damage to the module and back-light unit.
- (3) Note that polarizer is very fragile and could be easily damaged. Do not press or scratch the surface.
- (4) Do not allow drops of water or chemicals to remain on the display surface.
If you have the droplets for a long time, staining and discoloration may occur.
- (5) If the surface of the polarizer is dirty, clean it using some absorbent cotton or soft cloth.
- (6) The desirable cleaners are water, IPA (Isopropyl Alcohol) or Hexane.
Do not use ketene type materials (ex. Acetone), Ethyl alcohol, Toluene, Ethyl acid or Methyl chloride. It might permanent damage to the polarizer due to chemical reaction.
- (7) If the liquid crystal material leaks from the panel, it should be kept away from the eyes or mouth. In case of contact with hands, legs, or clothes, it must be washed away thoroughly with soap.
- (8) Protect the module from static; it may cause damage to the CMOS ICs.
- (9) Use finger-stalls with soft gloves in order to keep display clean during the incoming inspection and assembly process.
- (10) Do not disassemble the module.
- (11) Protection film for polarizer on the module shall be slowly peeled off just before use so that the electrostatic charge can be minimized.
- (12) Pins of I/F connector shall not be touched directly with bare hands.
- (13) Do not connect, disconnect the module in the "Power ON" condition.
- (14) Power supply should always be turned on/off by the item 6.1 Power On Sequence & 6.2 Power Off Sequence

9.2 Storage and Transportation.

- (1) Do not leave the panel in high temperature, and high humidity for a long time.
It is highly recommended to store the module with temperature from 0 to 35 °C and relative humidity of less than 70%
- (2) Do not store the TFT-LCD module in direct sunlight.
- (3) The module shall be stored in a dark place. When storing the modules for a long time, be sure to adopt effective measures for protecting the modules from strong ultraviolet radiation, sunlight, or fluorescent light.
- (4) It is recommended that the modules should be stored under a condition where no condensation is allowed. Formation of dewdrops may cause an abnormal operation or a failure of the module.
In particular, the greatest possible care should be taken to prevent any module from being operated where condensation has occurred inside.
- (5) This panel has its circuitry FPC on the bottom side and should be handled carefully in order not to be stressed.

Part. No	KD028WQRMD039-01	REV	V1.0	Page 27 of 28
	常备库存 Stock For Sale	长期供货 Long Time supply	支持小量 NO MOQ	品种齐全 In Full Range

10. Packing

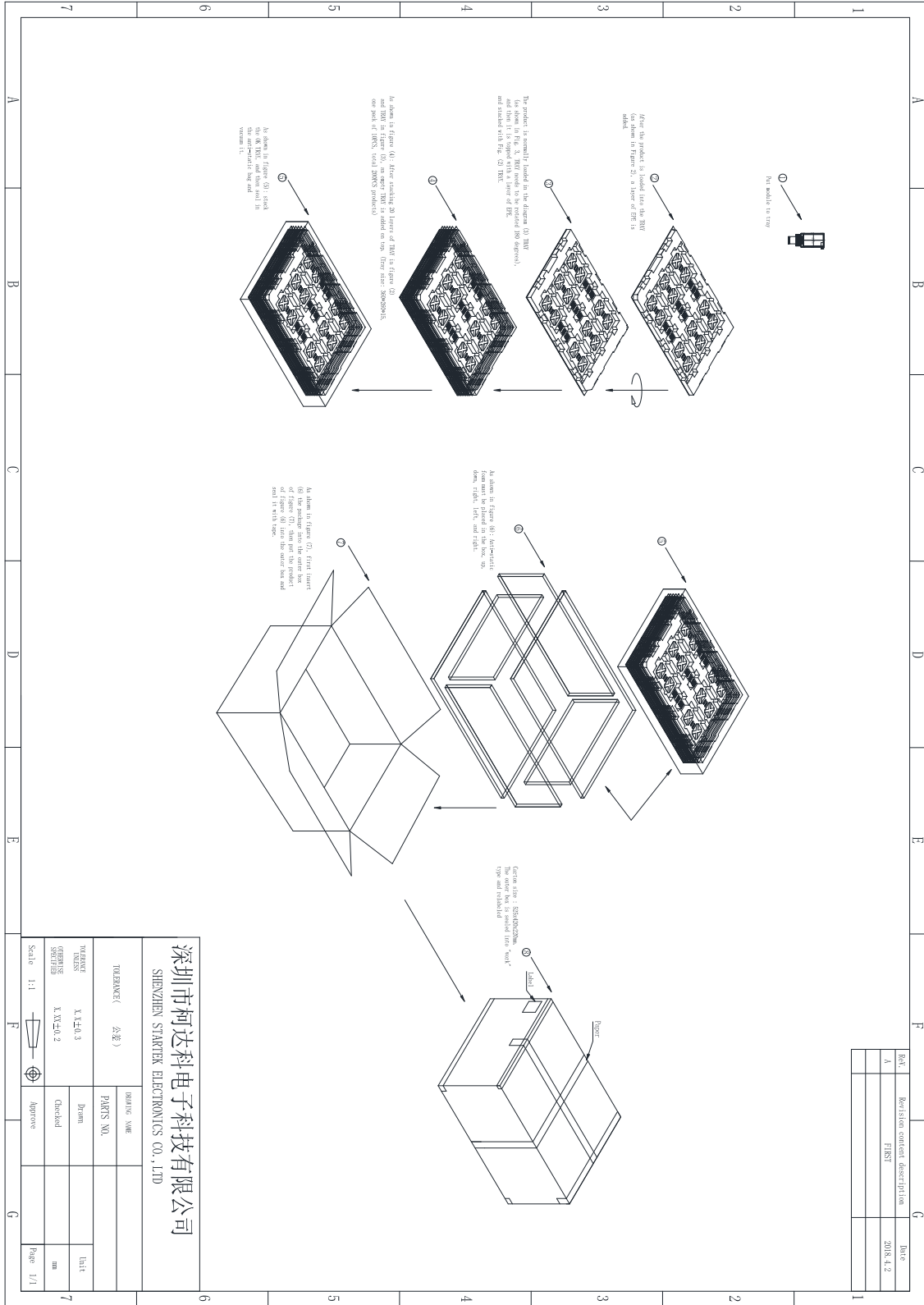

Part. No	KD028WQRMD039-01	REV	V1.0	Page 28 of 28
-----------------	-------------------------	------------	-------------	----------------------

常备库存
Stock For Sale
长期供货
Long Time supply
支持小量
NO MOQ
品种齐全
In Full Range